

CONTOUR: ELR TS

OAL: 33"

TEMPLATE: N/A

TAPER: SET TO .0185 IN 10 INCHES

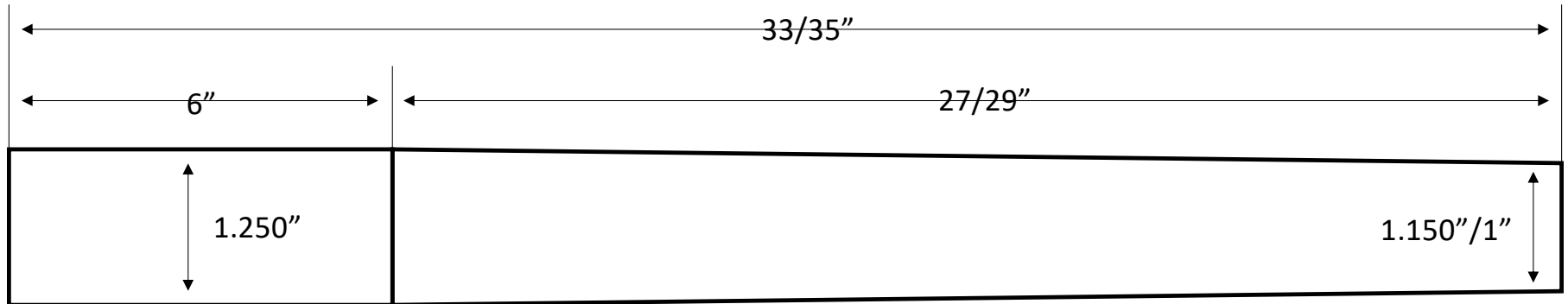

CONTOUR: Savage Custom

OAL: 32"

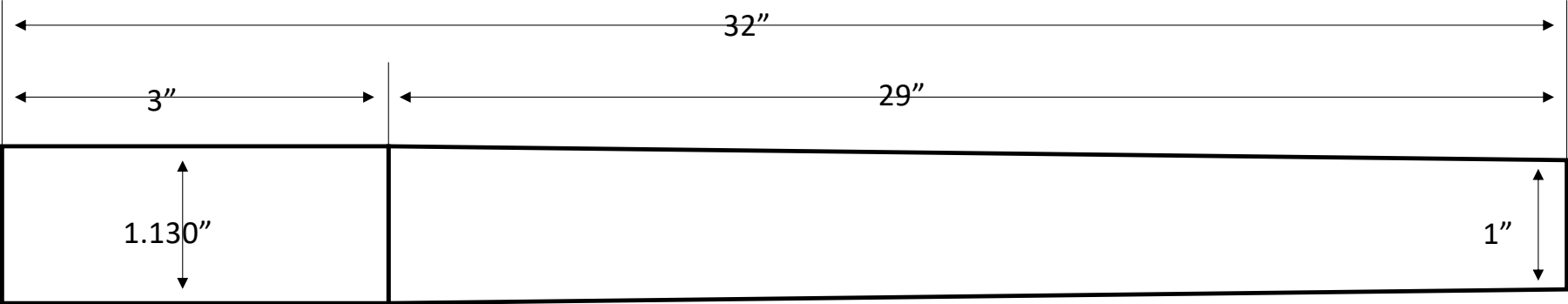

CONTOUR: SA custom ELR Light

OAL: 32"

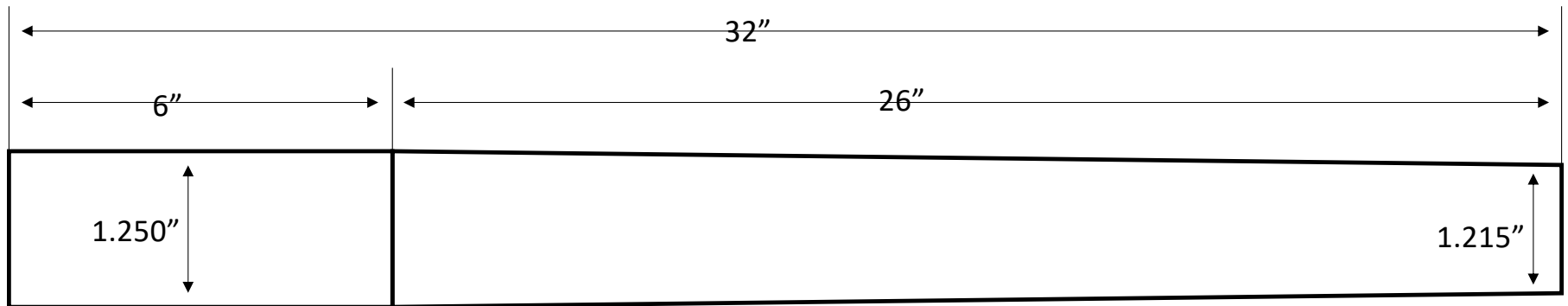

CONTOUR: Russell Custom

OAL: 40"

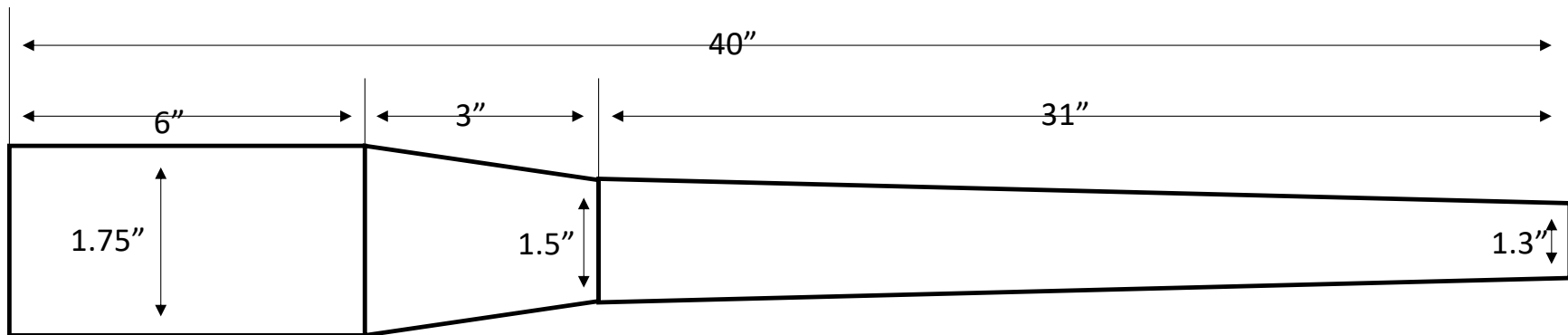

CONTOUR: SA custom ELR-L

OAL: 35"

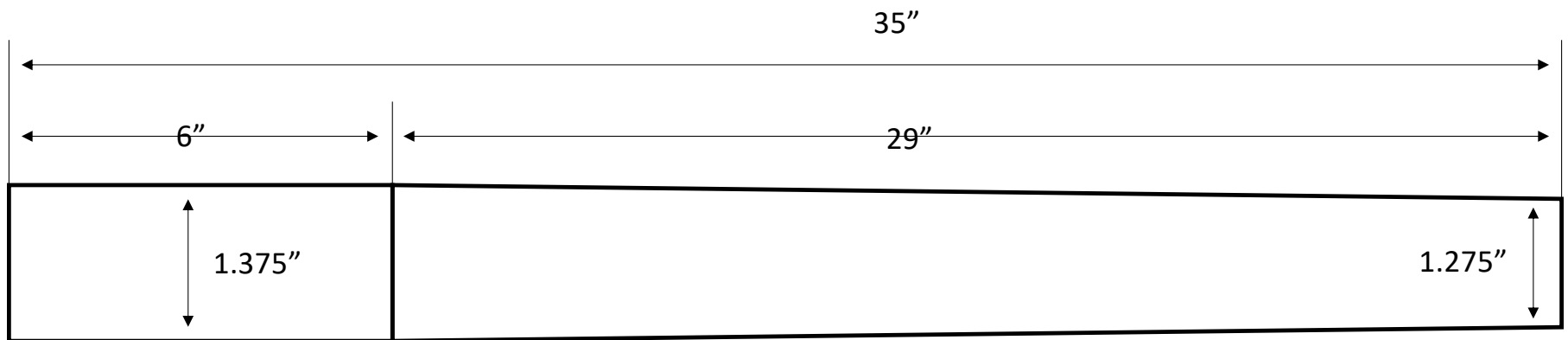

CONTOUR: SA custom ELR-M

OAL: 35"

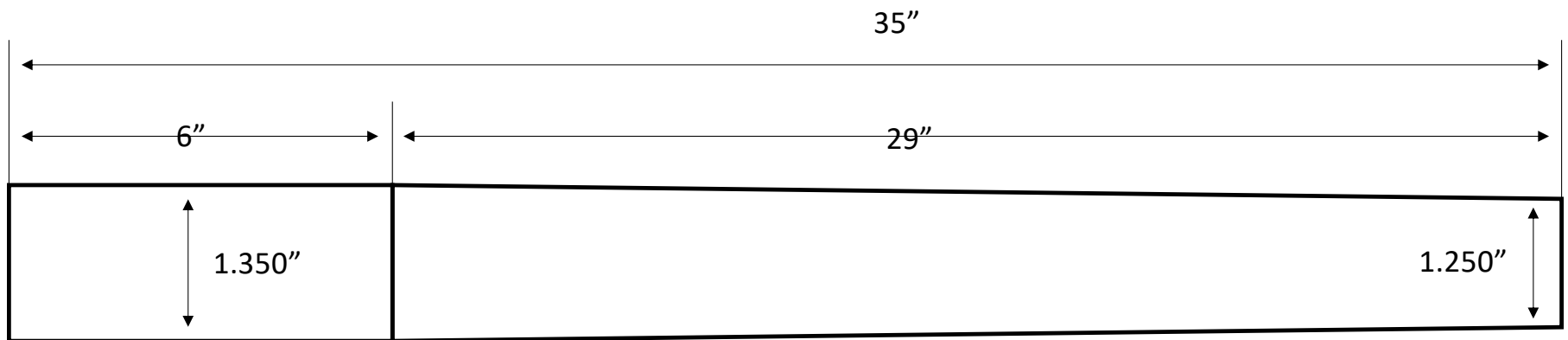

CONTOUR: SA custom ELR-S

OAL: 33"

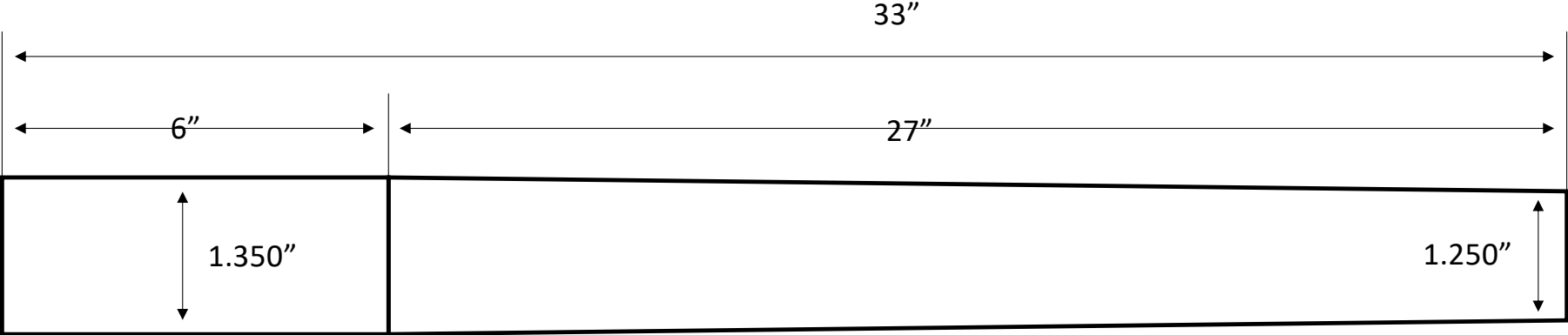

CONTOUR: Congdon Custom

OAL: 31"

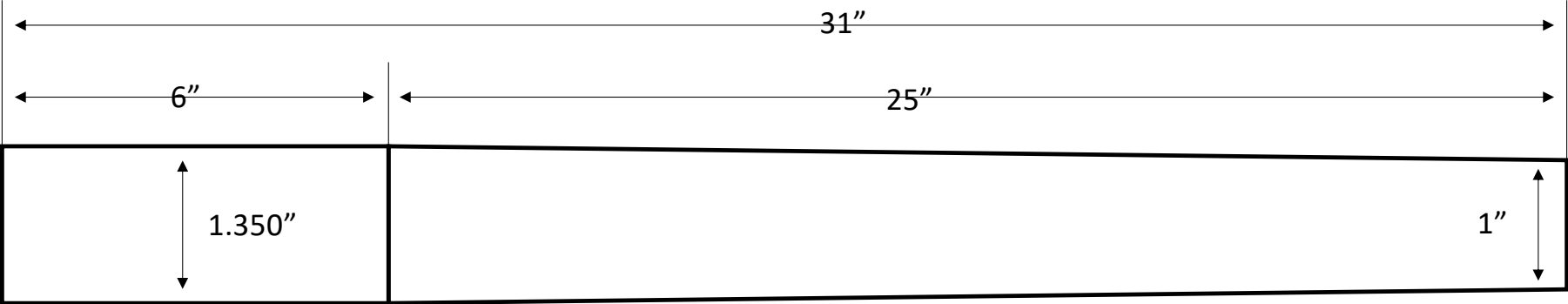



CONTOUR: Harless Custom

OAL: 33"

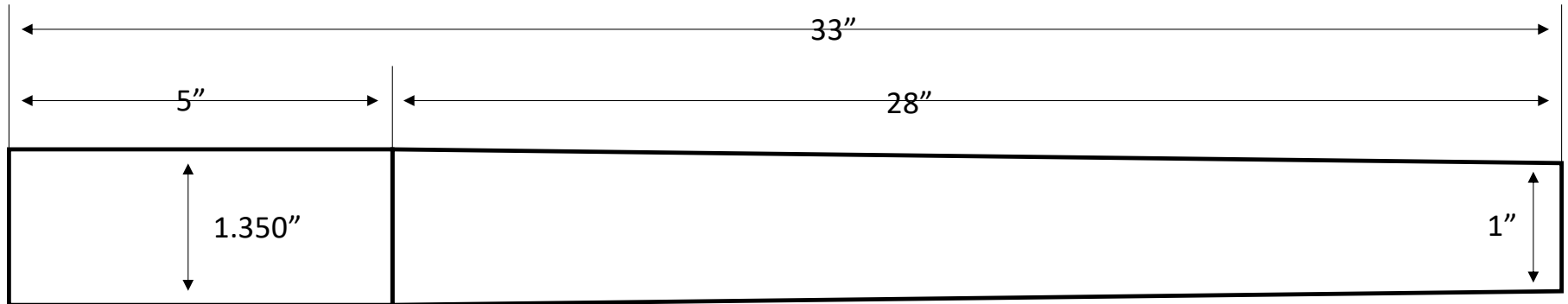

CONTOUR: M. GILLS CUSTOM

OAL: 34"

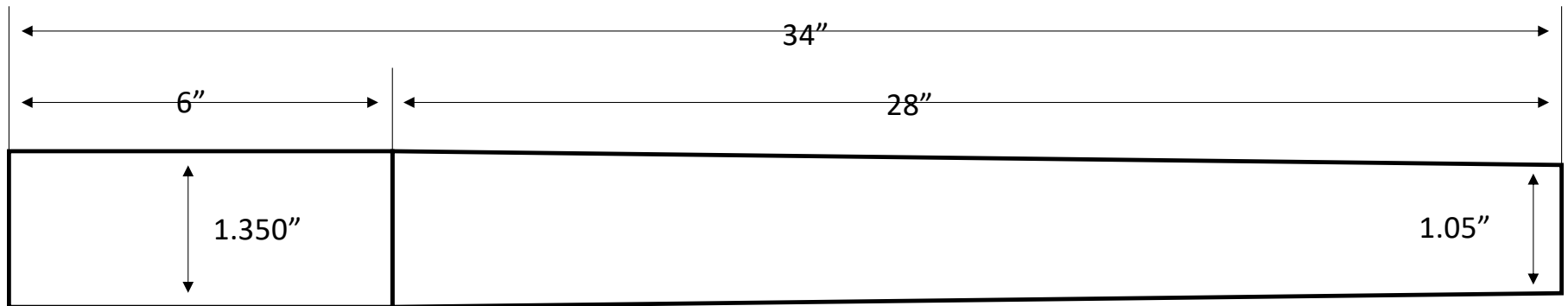

CONTOUR: M40-A3-A5

OAL: 26.5"

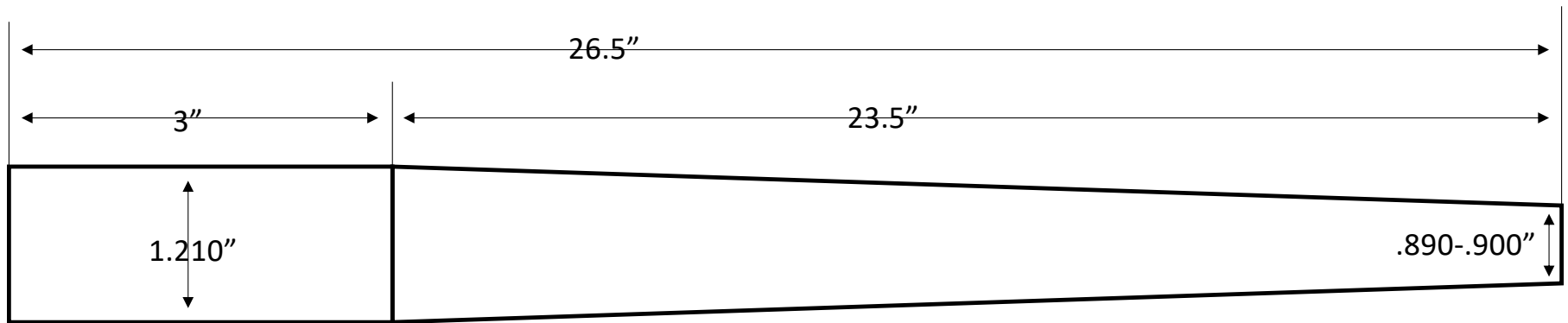

CONTOUR: M24

OAL: 26"

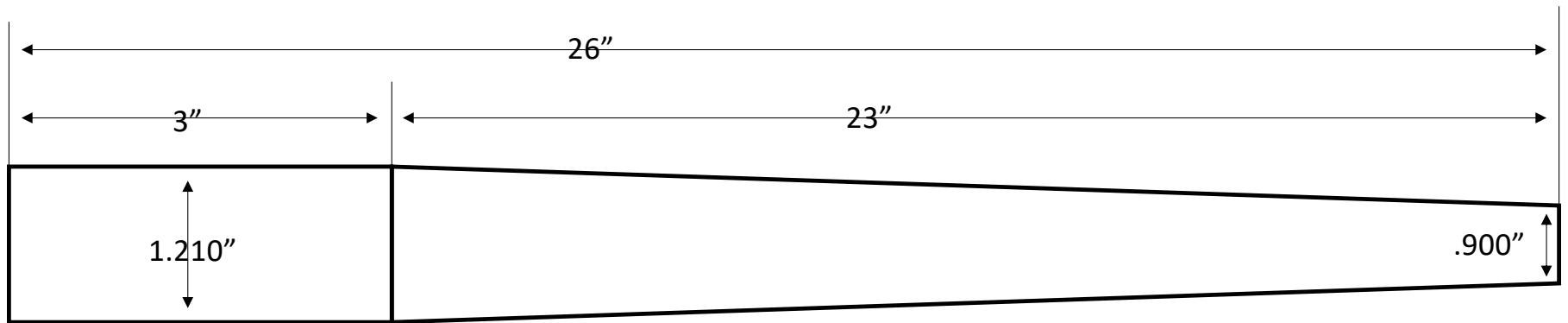

CONTOUR: MTU

OAL: 26"

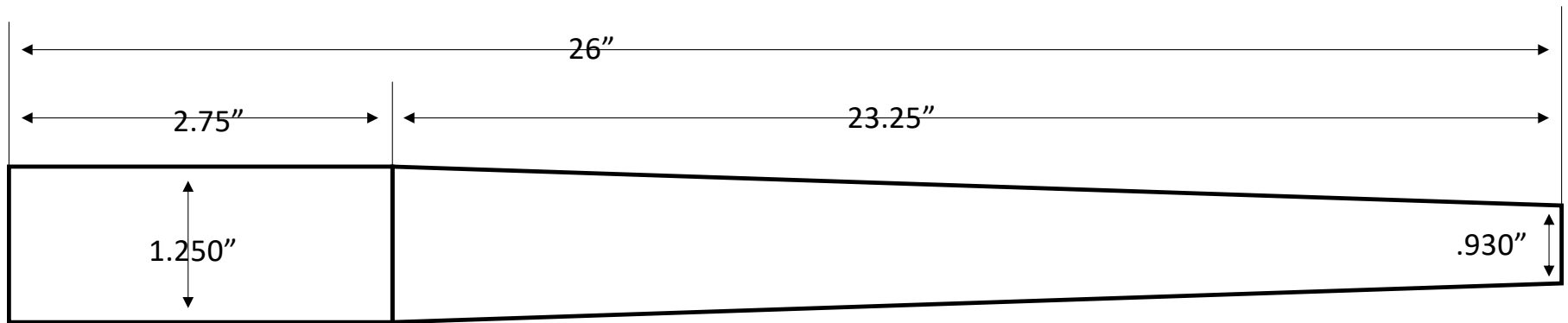

CONTOUR: USSS

OAL: 28"

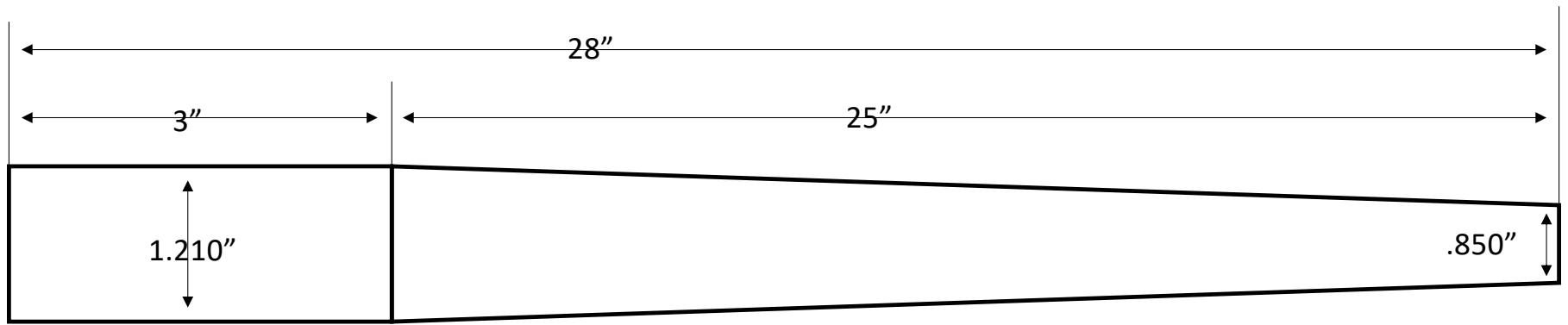

CONTOUR: HEAVY VARMINT

OAL: 28"

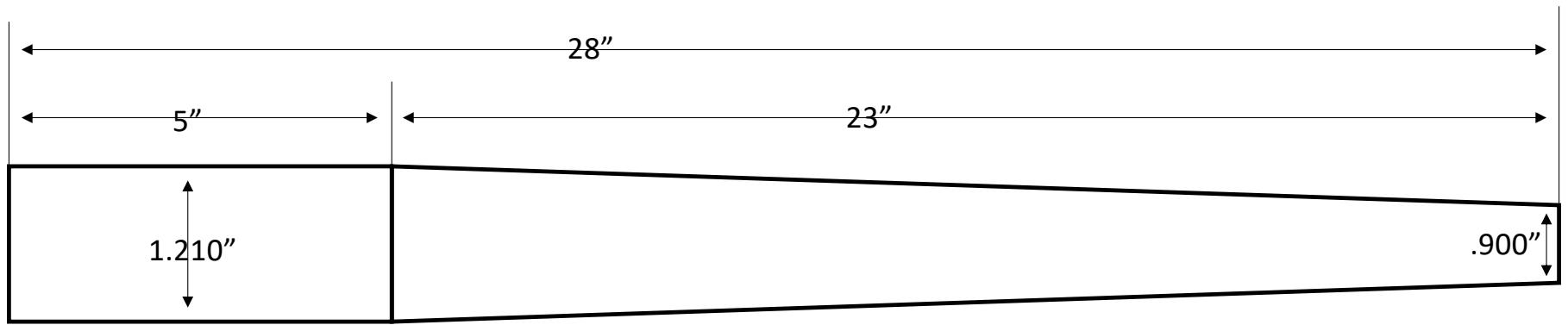

CONTOUR: LIGHT VARMINT

OAL: 28"

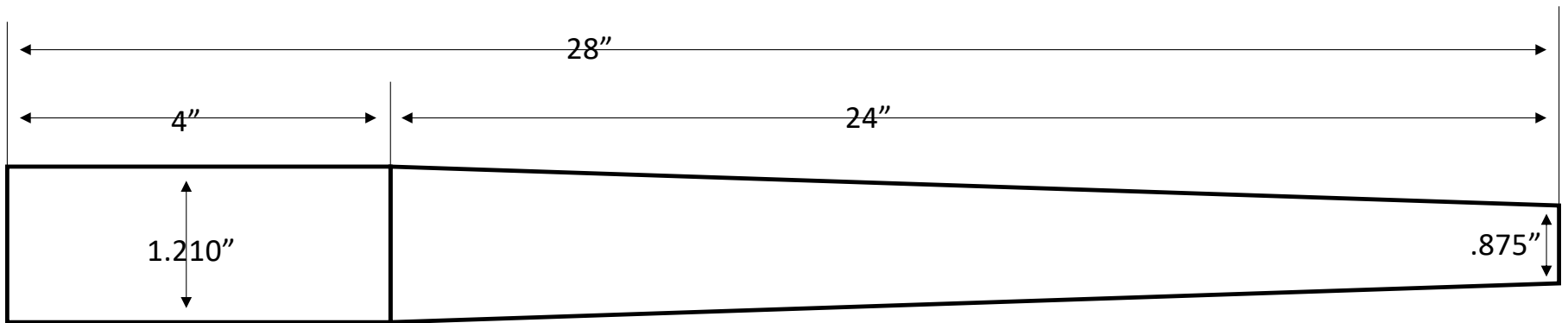



CONTOUR: MAX HEAVY VARMINT

OAL: 29"

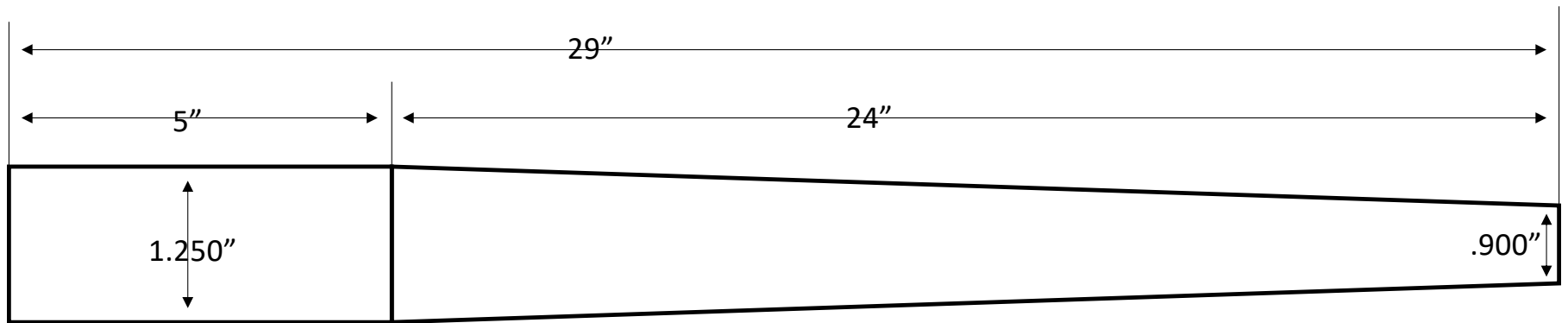

CONTOUR: Matt Harms

OAL: 34"

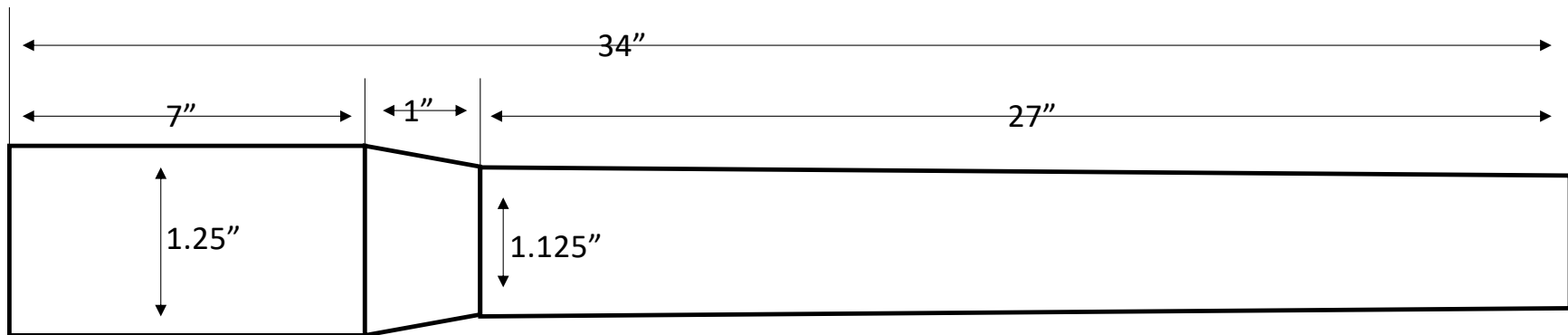

CONTOUR: SR60

OAL: 26"

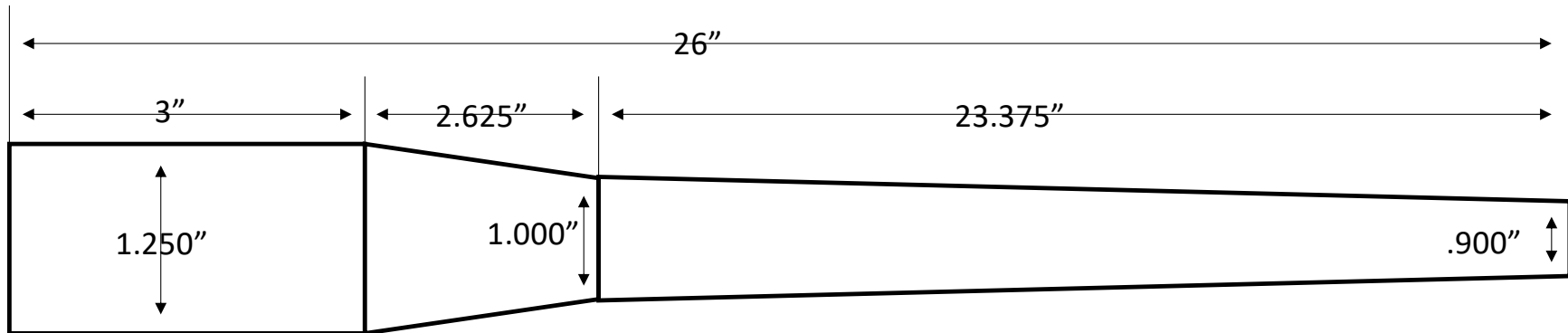

CONTOUR: HEAVY PALMA

OAL: 26"/28"/30"

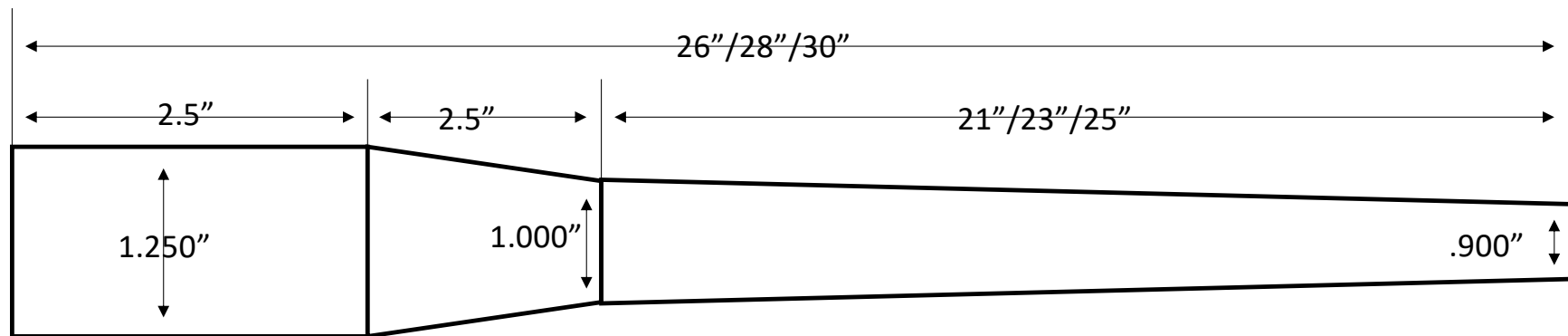

CONTOUR: MEDIUM PALMA

OAL: 26"/28"/30"

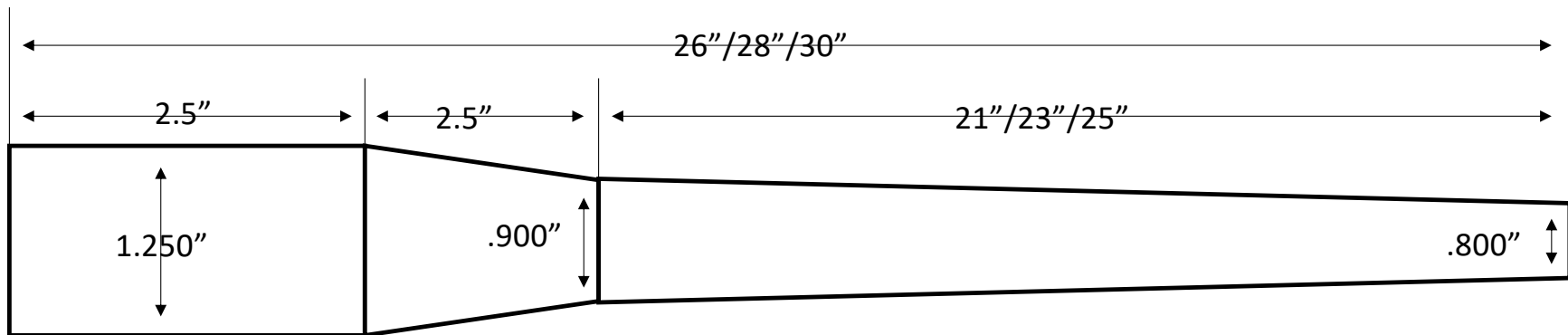

CONTOUR: LIGHT PALMA

OAL: 26"/28"/30"

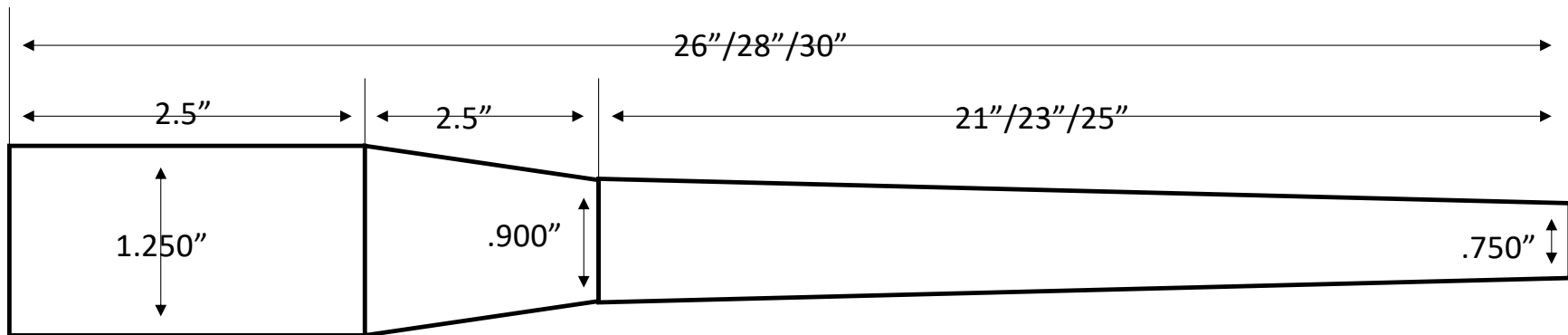

CONTOUR: TUBB T2K

OAL: 28"

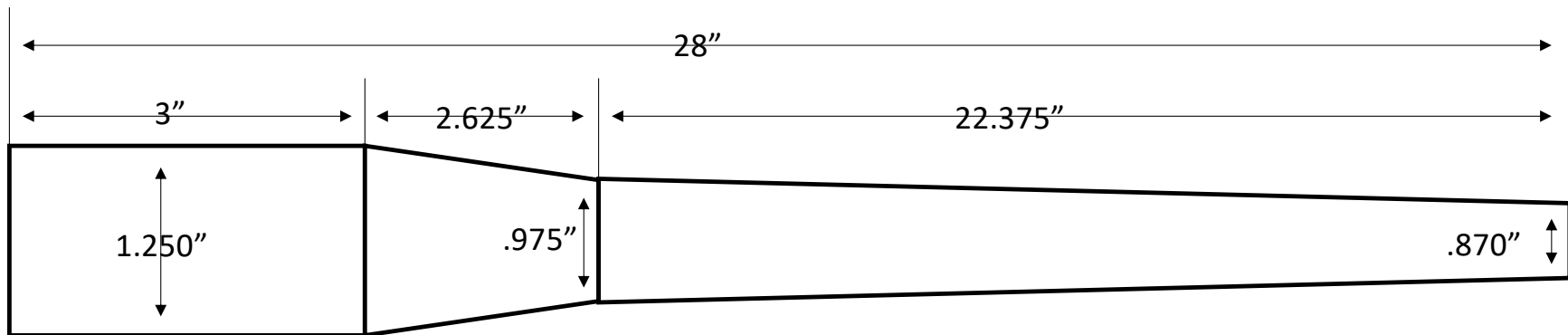

CONTOUR: SPEC TAC (STD)

OAL: 29"

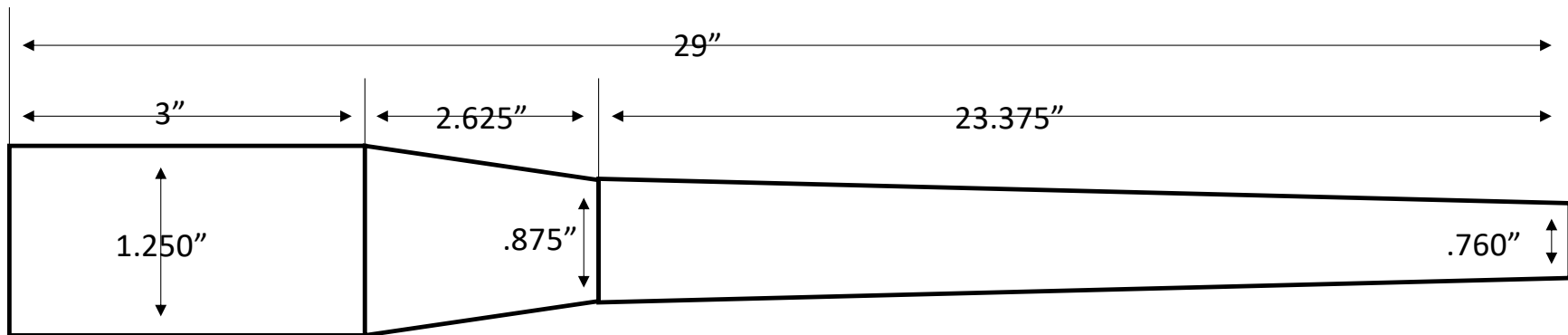



CONTOUR: REMINGTON VARMINT

OAL: 26"

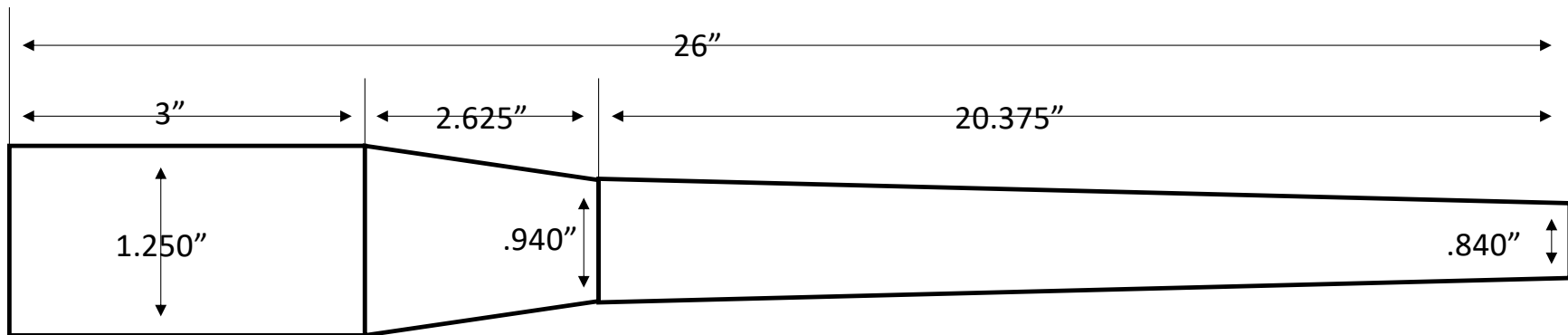

CONTOUR: TUBB ATR

OAL: 28"

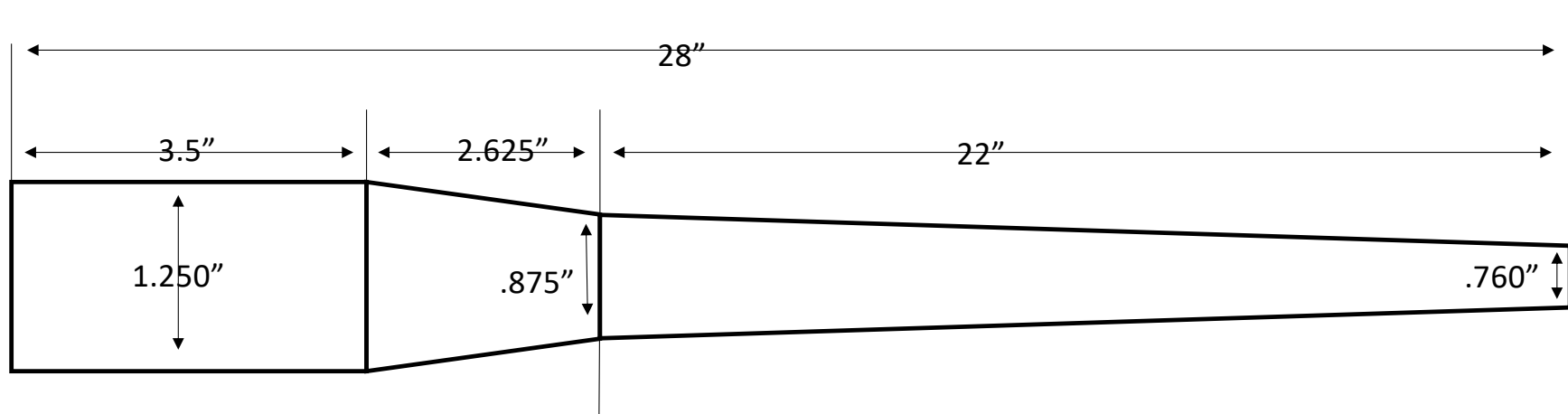

CONTOUR: SPORTER # 3

OAL: 28"

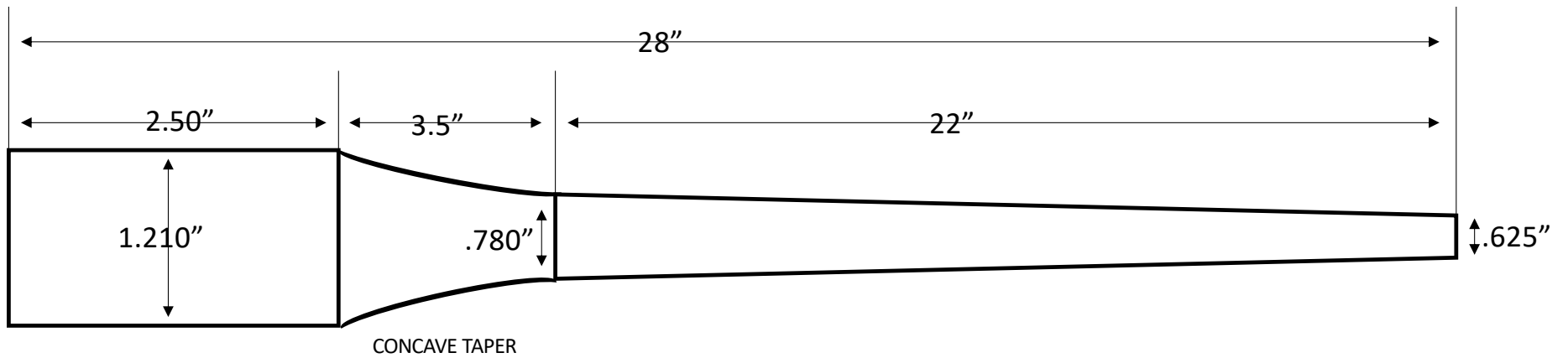

CONTOUR: SPORTER # 4

OAL: 28"

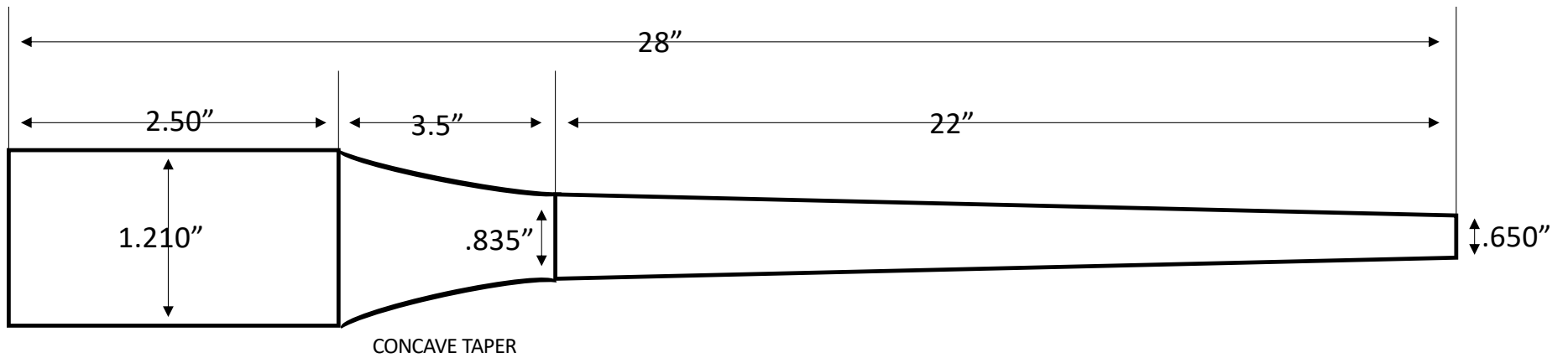

CONTOUR: SPORTER # 4.5

OAL: 28"

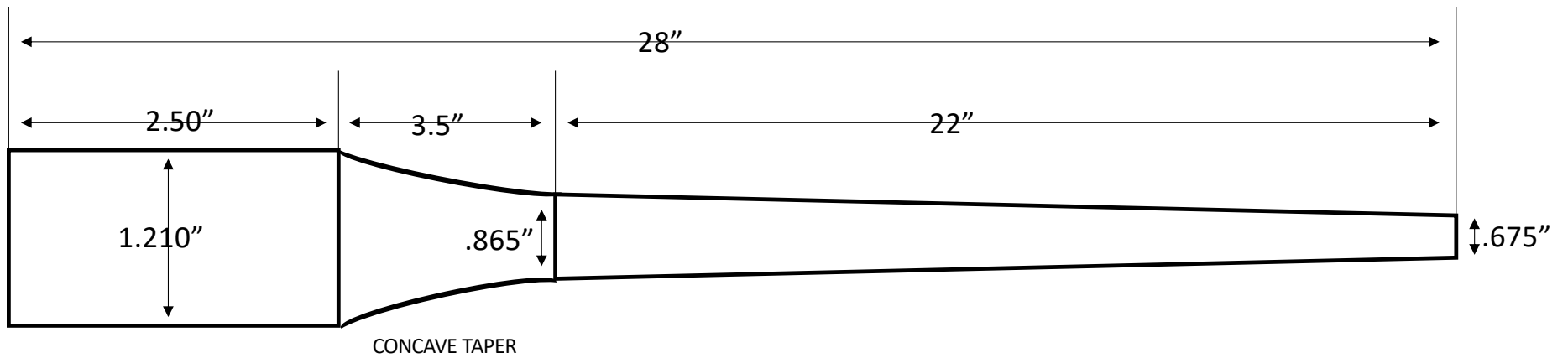

CONTOUR: SPORTER # 5

OAL: 28"

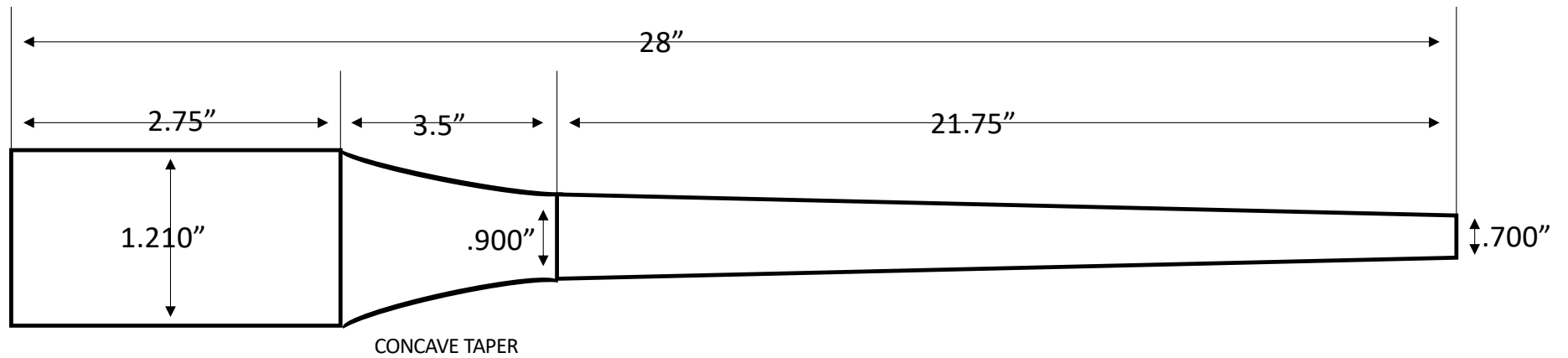

CONTOUR: SPORTER # 5.5

OAL: 28"

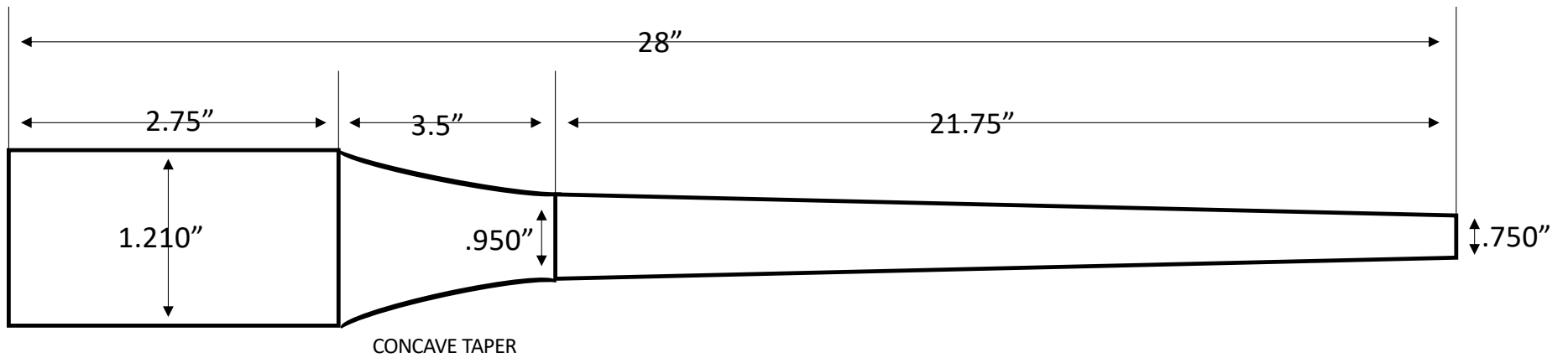

CONTOUR: Brumbaugh Custom

OAL: 30"

Extra inch on the front

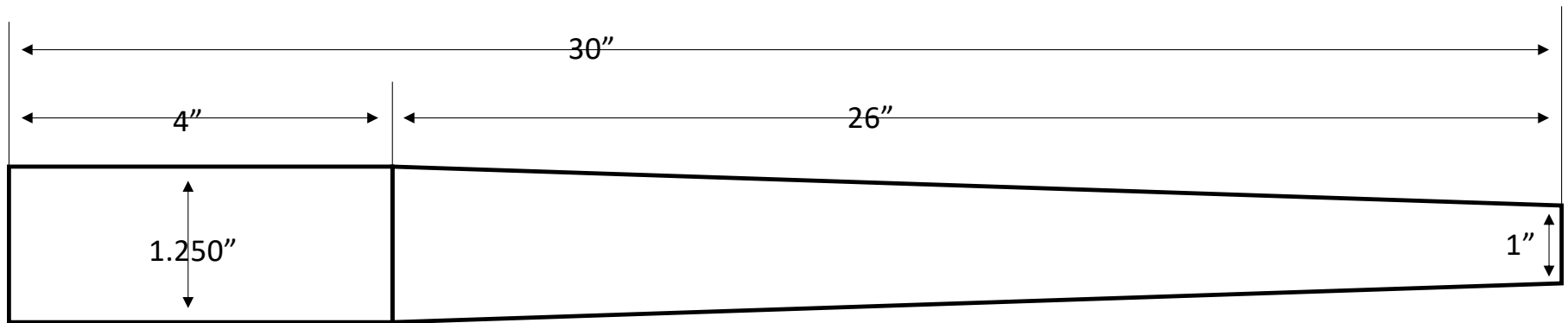



CONTOUR: Wink Custom

OAL: 35"

